



## PES-302 SEALED EDDY CURRENT PROXIMITY SENSOR

### User's Manual





## Safety Information

The following manual contains information and warnings that must be observed and followed in order to keep instruments in good condition and insure safe operation.

## Safety and Electrical Symbols

	<b>Warning - Danger</b> - Identifies conditions or practices that could cause physical harm or damage the measuring chain and other equipment to which it is connected.
	<b>Caution</b> - Identifies conditions or practices that could result in a permanent loss of data.
	<b>Important Information</b> - Must be read and followed.
	Shield connection location.

## Safety Precautions

<b>Warning - Danger</b> <b>Caution</b>
<ul style="list-style-type: none"><li>• To use the described sensors correctly and safely, read and follow all safety instructions or warnings displayed throughout this manual;</li><li>• This product is intended to be used by qualified operators and maintenance personnel who are familiar with the safety precautions required to avoid possible injury. Carefully read and follow all installation information before using this product;</li><li>• Install and use this product only as specified in this manual or the protection provided by this instrument might be impaired;</li><li>• When in doubt that safety protection has been impaired, make this product inoperative and secure it against any unintended operation;</li></ul>

This manual is provided solely for guidance. VibroSystM Inc. takes no responsibility or liability for any damage caused by accidents, improper installation or misuse. Liability is limited to the repair and/or replacement of defective products.

VibroSystM Inc. 2727 Jacques-Cartier E. Blvd, Longueuil, QC, Canada J4N 1L7 | Phone: 450 646-2157 | U.S. Toll-free Line: 800 663-8379

Email: [techsupp@vibrosystem.com](mailto:techsupp@vibrosystem.com) | [www.vibrosystem.com](http://www.vibrosystem.com)



## TABLE OF CONTENTS

<b>1. OVERVIEW OF THE PES-302 PROXIMITY SENSOR .....</b>	<b>5</b>
1.1 Description .....	5
1.2 Main Unit Interventions .....	5
<b>2. OPERATING THE PES-302 PROXIMITY SENSOR .....</b>	<b>6</b>
2.1 Connecting the PES-302 Sensor .....	6
2.2 Assessing the Actual Sensitivity .....	6
<b>3. SENSOR INSTALLATION INFORMATION .....</b>	<b>10</b>
3.1 Positioning the Sensors .....	10
3.2 Typical Installation .....	10
<b>4. GENERAL SPECIFICATIONS .....</b>	<b>11</b>
<b>5. TEMPLATE FOR RECORDING DISTANCE VALUES VS <math>I_{out}</math>.....</b>	<b>13</b>





## 1. OVERVIEW OF THE PES-302 PROXIMITY SENSOR

### 1.1 Description

PES-302 proximity sensors are designed for measuring the relative distance between the sensor's sensing face and metallic target surfaces. Its housing is sealed to sustain pressure up to 10 Bars [150 PSI] when submerged in oil, with a submersible integral cable.

The PES-302 covers a 0 to 2 mm [0 to 79 mils] measuring range.

### PES-302 Sensor

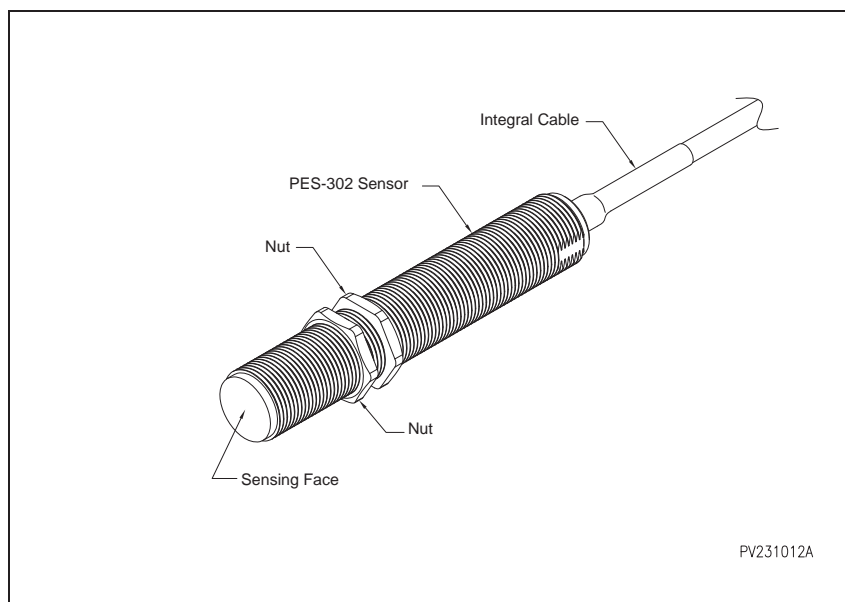

### 1.2 Main Unit Interventions

- Sensor holder must be bolted or welded at the appropriate location;
- The sensor's integral and extension cable must be routed and protected from the sensor to the acquisition unit.

#### **Caution**

- Instructions for sensor installation and connection must be thoroughly followed to ensure a safe and proper operation;
- In order to complete the commissioning, VibroSystem must be contacted when Section 2.2 (Assessing the actual sensitivity) is reached.

## 2. OPERATING THE PES-302 PROXIMITY SENSOR

### 2.1 Connecting the PES-302 Sensor

Connect the sensor as displayed in the following wiring diagram:

#### Wiring Diagram

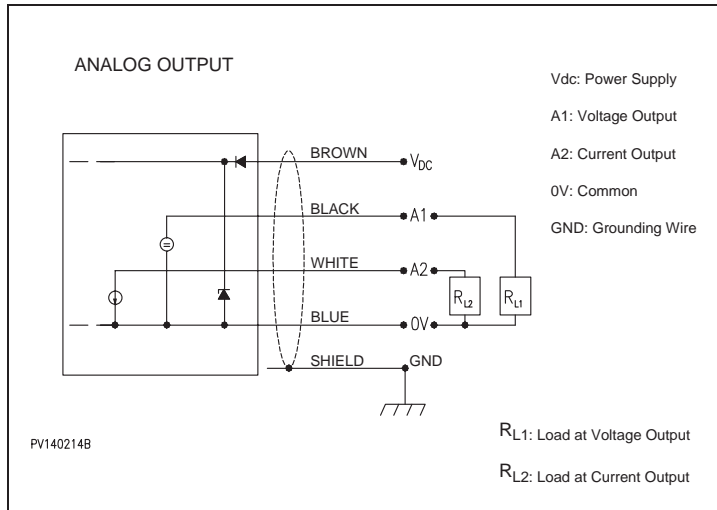

#### ! Important Information

- The integral cable shield **IS NOT** connected to the sensor's metallic casing body. It must always be grounded on the instrumentation side.

### 2.2 Assessing the Actual Sensitivity

PES-302 proximity sensors are calibrated to produce a linearized output based on an FE360 steel target. Because the sensitivity of eddy-current sensors is affected by the nature of the material used as a target, the actual sensitivity must be determined.

#### ! Important Information

- Failure to correctly assess and compensate the sensitivity will result in incorrect measurement results as expressed in the illustration below.

#### PES-302 Calculated Distance vs Sensor Current Output

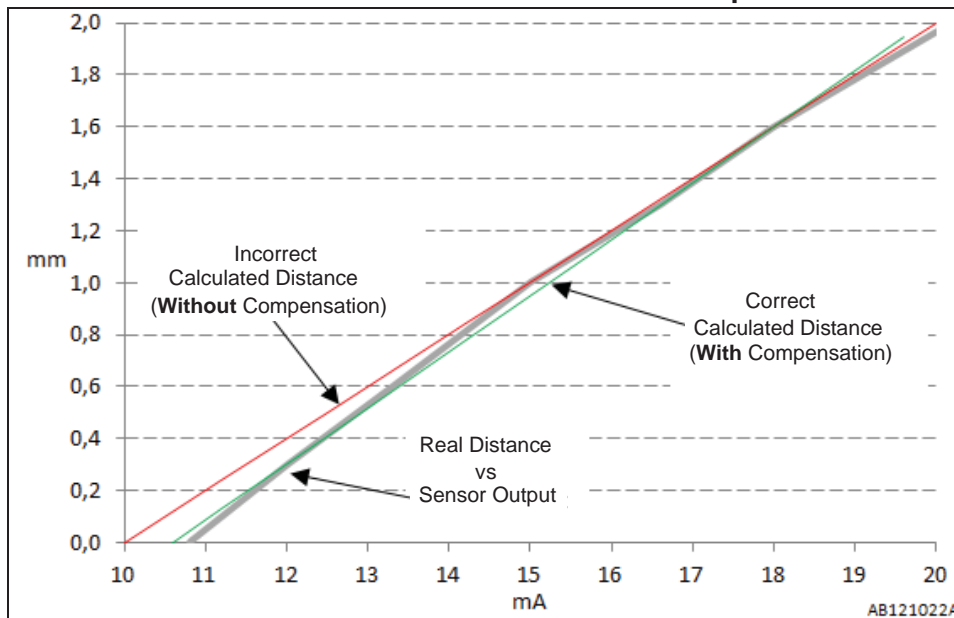



## ! Important Information

- Step 1 must be completed BEFORE installing the sensor. Steps 2, 3, and 4 must be completed AFTER installing the sensor;
- In the examples below, calculations are in metric format. All distances can also be measured in inches with the resulting values used in the same formulas.

### Step 1 - Measuring Current Output ( $I_{out}$ ) and Corresponding Distance

To assess the sensor’s actual sensitivity, physical distance and current measurements must first be taken using a target made of the **same material** as the real target. Minimum dimensions for the target are: 50mm x 50mm x 2mm [2" x 2" x 1/16"].

Proceed as follows:

Fill the table with measurements (distance vs current), equally distributed on the full current scale. Add **non-metallic** spacers between the sensor’s tip and the target until  $I_{out}$  max. is approximately reached. Note down the current value and the distance (total thickness of spacers) in the table. Gradually remove spacers to approximately reach the next  $I_{out}$  level and again, write down the current value and distance. Repeat until the table is filled. The last  $I_{out}$  value is measured without spacers (0mm), with the sensor’s tip placed directly against the target.

### Recorded Distance Values vs $I_{out}$ for PES-302

<i>Ideal level of <math>I_{out}</math> (mA)</i>	20	17.5	15	12.5	10
<i>Measured <math>I_{out}</math> (mA)</i>					
<i>Measured distance (mm)</i>					0

### Example of Recorded Distance Values vs $I_{out}$ for PES-302

		$I_{out B}$	$I_{op}$ approx.	$I_{out A}$	
		↓	↓	↓	
<i>Measured <math>I_{out}</math> (mA)</i>	20.35	16.58	15.04	13.3	10.62
<i>Measured distance (mm)</i>	2	1.3	1	0.6	0
		↑		↑	
		$d_B$		$d_A$	



## Step 2 - Taking a Measurement with the Sensor Installed

With the sensor now installed, take a measurement and note the real operating current ( $I_{op}$ ).

### ! Important Information

- For best results, the sensor should be installed at a distance corresponding to the middle of the measuring range when the target is stationary (unit stopped).

Example with PES-302:  $I_{op} = 15.04$  mA

## Step 3 - Calculating the Sensitivity

Select two points in the table, on either side of the value closest to  $I_{op}$ . These two points (A & B) will be used to define the linear equation. The selected points should be at equal distance from  $I_{op}$  (ideally, point A at  $I_{op} - 2.5$  mA, and point B at  $I_{op} + 2.5$  mA).

If  $I_{op} = 15.04$  mA:

Point A:  $I_{op} - 2.5$  mA = 12.54 mA (closest correspondence in the table:  $I_{outA} = 13.3$  mA,  $d_A = 0.6$  mm)

Point B:  $I_{op} + 2.5$  mA = 17.54 mA (closest correspondence in the table:  $I_{outB} = 16.58$  mA,  $d_B = 1.3$  mm)

a) Calculate «**m**» (the sensitivity or gain), using selected points A and B.

$$m = \frac{d_B - d_A}{I_{outB} - I_{outA}}$$

Example for PES-302:

$$m = \frac{1.3 - 0.6}{16.6 - 13.3} = \frac{0.7}{3.3} = \mathbf{0.212}$$

b) Calculate «**b**» (the y-intercept) of the linear equation, using calculated «**m**», measured current  $I_{out}$  and measured distance «**d**» corresponding to point A, or point B.

$$b = d - (m \times I_{out})$$

Example for PES-302  
(with point B):

$$b = 1.3 - (0.212 \times 16.6) = \mathbf{-2.219 \text{ mm}}$$

c) The equation to calculate the compensated distance corresponding to the sensor's current output is:

$$d_C = (m \times I_{out}) + b$$

Where:

$d_C$  is the calculated distance (in mm)





- d) Verify the «**m**» and «**b**» calculated values by applying the following formula on the measured value between the **A** and **B** coordinates:

for  $I_{out} = 15.04$  mA, verify that  $d_C = 1$  mm ( $\pm 5\%$  of range):

$$d_C = (0,212 \times 15,04) - 2,219 = 0.969 \text{ mm}$$

### Step 4 - Adjustment Through the ZOOM Configuration Software

Proceed with the final adjustment through the ZOOM Configuration software. Select **Sensor Configuration**, and in the **Range** tab of the dialog window, enter the **Maximum** and **Minimum** values of the **Raw output range**.

#### Formulas for Adjustment of the Raw Output Range

The screenshot shows the 'Sensor Configuration [PES-302]' dialog window with the 'Range' tab selected. The 'Raw output range' section contains the following fields:

- Maximum: 2
- Minimum: 0
- Offset: 0

Callouts from external boxes point to the Maximum and Minimum fields with the following formulas:

- Maximum = (m x 20 mA) + b
- Minimum = (m x 10 mA) + b

Note: In the **Trending and alarm range** section, the Maximum and Minimum values must be within the limits of the **Raw output range**.

#### Example with Calculated Values

The screenshot shows the 'Sensor Configuration [PES-302]' dialog window with the 'Range' tab selected. The 'Raw output range' section contains the following fields:

- Maximum: 2.02
- Minimum: -0.10
- Offset: 0

Callouts from external boxes point to the Maximum and Minimum fields with the following formulas:

- Maximum = (0.212 x 20 mA) - 2.219
- Minimum = (0.212 x 10 mA) - 2.219

### 3. SENSOR INSTALLATION INFORMATION

#### 3.1 Positioning the Sensors

 **Caution**

- The PES-302 sensor must be properly connected with its cable well protected to avoid any sort of mechanical damage.

Before determining where to install the sensor, consider the following:

- The sensor's surface must face the target;
- The maximum cable length (integral cable + extension) must be considered. From the sensor to the acquisition unit, the maximum distance is 300 m [984 ft] for the current output, and 100 m [328 ft] for the voltage output.

 **Important Information**

- VibroSystM recommends relying on the services of a trained technician for supervising the installation of these proximity sensors and finalizing the ZOOM software configuration.

#### 3.2 Typical Installation

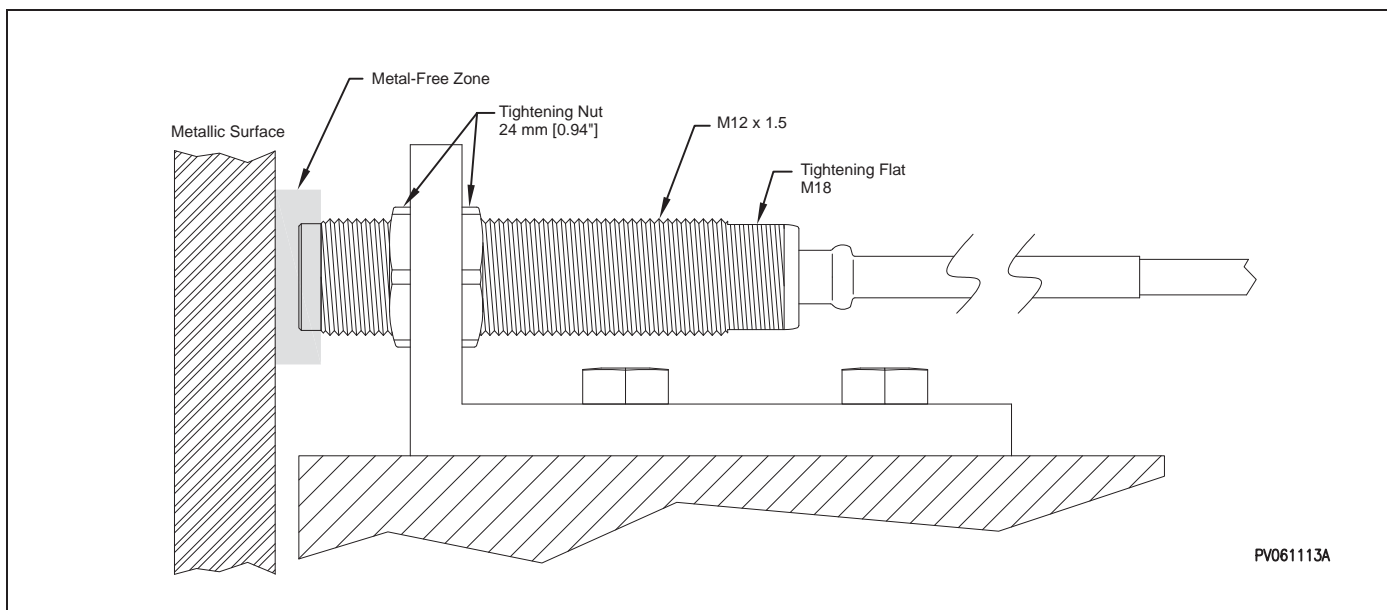



## 4. GENERAL SPECIFICATIONS

### Operation

• Measurement Type	Non-Contact Proximity, Eddy Current
• Measuring Range*	0 to 2 mm [0 to 79 mils]
• Outputs*	10 to 20 mA 4 to 10 V
• Sensitivity*	5 mA/mm [127 $\mu$ A/mil] 3 V/mm [76 mV/mil]
• Accuracy**	$\pm$ 10%
• Repeatability	$\pm$ 5%
• Bandwidth	0 to 1000 Hz (-3dB)
• Load at Current Output	500 $\Omega$ max.
• Load at Voltage Output	10 k $\Omega$ min.
• Temperature Drift	< 10%
• Short Circuit Protection	Built-In
• Certification	GOST Russia - Pattern Approval Certificate for Measuring Instruments

### Power Requirements

• Voltage	15 to 30 Vdc
• Consumption	30 mA max.
• Voltage Reversal Protection	Built-In
• Warm-Up Time	5 Minutes

### Connection

• Integral Cable Type	4-Wire x 0.34 mm <sup>2</sup> [22 AWG] Shielded
Outer Jacket Material	PUR (Polyurethane)
Outer Jacket Diameter	5.9 mm [0.232 in]
Length	30 m [98.4 ft]
Min. Bending Radius	60 mm [2.36 in]
• Max. Cable Length (Integral + Extension)	
For Current Output	300 m [984 ft]
For Voltage Output	100 m [328 ft]

### Environment

• Temperature Range	
Operating	0 to 70°C [32 to 158°F]
Storage	-25 to 70°C [-13 to 158°F]
• Max. Submersible Pressure	10 Bar [150 PSI]
• Protection Rating	IP69

### Physical Characteristics

• Sensor Body	Chrome-Plated Brass
• Sensing Face	Polyamide-imide

## Dimensions

\*Target material: FE360 steel

\*\*With appropriate correction factor

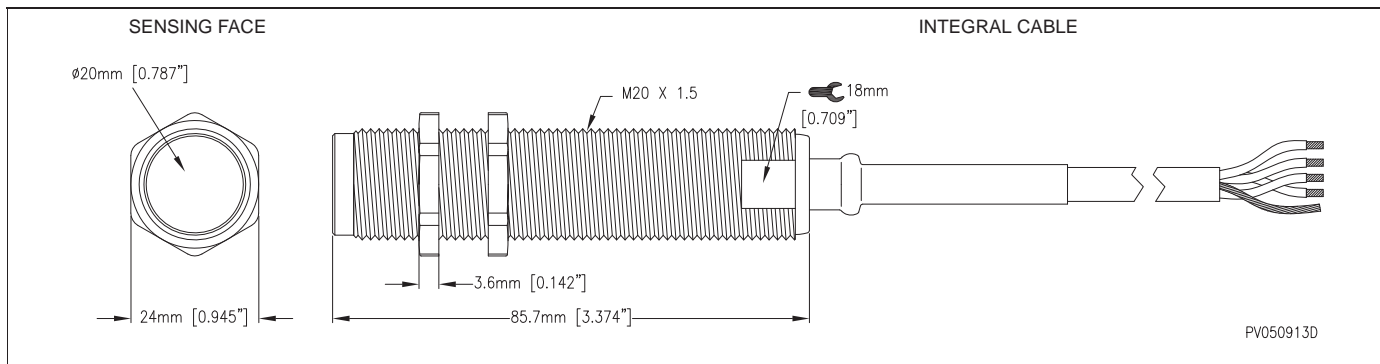





### 5. TEMPLATE FOR RECORDING DISTANCE VALUES VS $I_{out}$

Unit no.: \_\_\_\_\_ Sensor S/N: \_\_\_\_\_ Position: \_\_\_\_\_

<i>Measured <math>I_{out}</math> (mA)</i>					
<i>Measured distance (mm)</i>					0

Unit no.: \_\_\_\_\_ Sensor S/N: \_\_\_\_\_ Position: \_\_\_\_\_

<i>Measured <math>I_{out}</math> (mA)</i>					
<i>Measured distance (mm)</i>					0

Unit no.: \_\_\_\_\_ Sensor S/N: \_\_\_\_\_ Position: \_\_\_\_\_

<i>Measured <math>I_{out}</math> (mA)</i>					
<i>Measured distance (mm)</i>					0

Unit no.: \_\_\_\_\_ Sensor S/N: \_\_\_\_\_ Position: \_\_\_\_\_

<i>Measured <math>I_{out}</math> (mA)</i>					
<i>Measured distance (mm)</i>					0

Unit no.: \_\_\_\_\_ Sensor S/N: \_\_\_\_\_ Position: \_\_\_\_\_

<i>Measured <math>I_{out}</math> (mA)</i>					
<i>Measured distance (mm)</i>					0

Unit no.: \_\_\_\_\_ Sensor S/N: \_\_\_\_\_ Position: \_\_\_\_\_

<i>Measured <math>I_{out}</math> (mA)</i>					
<i>Measured distance (mm)</i>					0